

PERFORMANCE OF ORTHOGONAL FREQUENCY DIVISION MULTIPLEXING (OFDM) UNDER THE EFFECT OF WIRELESS TRANSMISSION SYSTEM DRAWBACKS

Mohamed Ahmed Mohamedian¹, Iman Abuel Maaly A/Elrahman¹
and Izz Eldin Mohamed Osman²

¹ Dept. of Electrical and Electronic Eng., University of Khartoum, P.O.Box 321, Khartoum, Sudan,
² Sudan University of Science and Technology, Khartoum, Sudan

Received June. 2007, accepted after revision September. 2007

مُسْتَخْلَص

تعتبر تكنولوجيا مقسم التردد المتعامد والمتعدد الإرسال (OFDM) مفتاح البراءة التقنية، وذلك لمقدرته لتحقيق معدل بيانات عالية، وتحقيق المتطلبات الفعالة لأنظمة الاتصالات اللاسلكية على النحو القريب. تقدم هذه الورقة نموذج محاكاة لنظام (OFDM) تم تصميمه باستخدام برنامج (MATLAB & Simulink). تم استخدام معدلات تخطيط مختلفة مثل BPSK, QPSK, DBPSK, DQPSK, 8PSK, 16PSK.

تم التركيز في مخطط التعديل DQPSK وذلك لمقدرته لتحقيق سعة بيانات عالية والحصول على إشارة ذات كفاءة وإداء جيد. وفي جزء من هذه الورقة تم التحقيق في تأثير معوقات الإرسال اللاسلكي على نظام OFDM. وايضا تقدم الورقة كيفية تعامل نظام OFDM مع معوقات الإرسال اللاسلكي مثل تعدد المسارات في الإشارات والتأخير الموجي وظاهرة دوبلر (Doppler shift).....

ABSTRACT

Orthogonal Frequency Division Multiplexer (OFDM) technology is a key technique for achieving the high data rate and spectral efficiency requirements for wireless communication systems of the near future. This paper presents a modeling and simulation of OFDM by MATLAB & Simulink. Different modulation schemes have been used, such as BPSK, QPSK, DBPSK, DQPSK, 8PSK and 16PSK. The paper concentrated on Differential Quadrature Phase Shift Keying (DQPSK) as a modulation scheme since it achieved high data rate and very good performance. As part of this, an investigation of detrimental effects of wireless transmission system drawbacks on OFDM is presented, showing the effect of band pass filtering, Additive White Gaussian Noise (AWGN) on modulation Bit Error Rate (BER). The paper also presents how OFDM deal with other transmission drawbacks such as attenuation, multipath, delay spread and Doppler shift...

Keywords: Multipath channels, orthogonal frequency division multiplexing (OFDM), Intersymbol interference (ISI), Additive white gaussian noise (AWGN), Differential quadrature phase shift keying (DQPSK).



1. INTRODUCTION

The name 'OFDM' is derived from the fact that the digital data is sent using many carriers, each of a different frequency (Frequency Division Multiplexing) and these carriers are orthogonal to each other, hence Orthogonal Frequency Division Multiplexing [1].

It is a modulation scheme that allows digital data to be efficiently and reliably transmitted over a radio channel, even in multipath environments. OFDM transmits data by using a large number of narrow bandwidth carriers [1]. These carriers are regularly spaced in frequency, forming a block of spectrum. The frequency spacing and time synchronization of the carriers are chosen in such a way that the carriers are orthogonal, meaning that they do not cause interference with each other. This is despite the carriers overlapping with each other in the frequency domain.

The origins of OFDM development started in the late 1950's [2] with the introduction of Frequency Division Multiplexing (FDM) for data communications. In 1966 Chang patented the structure of OFDM [2] and published the concept of using orthogonal overlapping multi-tone signals for data communications. In 1971 Weinstein [2] introduced the idea of using a Discrete Fourier Transform (DFT) for implementation of the generation and reception of OFDM signals, eliminating the requirement for banks of analogue sub carrier oscillators. This presented an opportunity for an easy implementation of OFDM, especially with the use of Fast Fourier Transforms (FFT), which are an efficient implementation of the DFT. This suggested that the easiest implementation of OFDM is with the use of Digital Signal Processing (DSP), which can implement FFT

algorithms. It is only recently that the advances in integrated circuit technology have made the implementation of OFDM cost effective. The reliance on DSP prevented the wide spread use of OFDM during the early development of OFDM.

The basic principle of OFDM is to split a high-rate data stream into a number of lower rate streams that are transmitted simultaneously over a number of sub carriers as shown in figure1. The relative amount of dispersion in time caused by multipath delay spread is decreased because the symbol duration increases for lower rate parallel sub carriers. The intersymbol interference is being eliminated completely by introducing a guard time in every OFDM symbol. This means that in the guard time, the OFDM symbol is cyclically extended to avoid intercarrier interference [1].

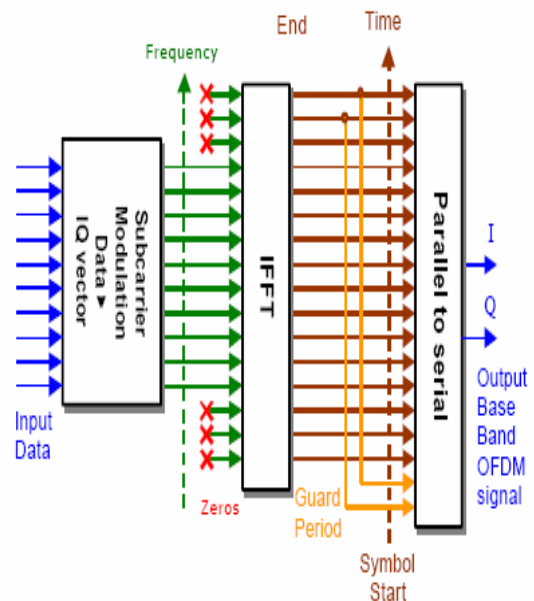

Figure 1: Generation of OFDM System

An OFDM signal is a sum of sub carriers that are individually modulated by using phase shift keying (PSK) or quadrature amplitude modulation



(QAM). The symbol can be written as [1, 3]:

$$S(t) = R_e \left\{ \sum_{i=N_s/2}^{((N_s/2)-1)} d_{(i+N_s/2)} \exp \left(j2\pi \left(f_c - \frac{i+0.5}{T} \right) (t-t_s) \right) \right\} , t_s \leq t \leq t_s + T \quad (1)$$

$$S(t) = 0 , t < t_s \text{ and } t > t_s + T$$

Where:

N_s is number of sub channels

T is the symbol duration

f_c is carrier frequency

The equivalent complex base band notation is given by:

$$S(t) = \sum_{i=N_s/2}^{((N_s/2)-1)} d_{(i+N_s/2)} \exp \left(j2\pi \frac{i}{T} (t-t_s) \right) , t_s \leq t \leq t_s + T \quad (2)$$

$$S(t) = 0$$

$$, t < t_s \text{ and } t > t_s + T$$

In this case, the real and imaginary parts correspond to the in-phase and quadrature parts of the OFDM signal. They have to be multiplied by a cosine and sine of the desired frequency to produce the final OFDM signal as shown in figure2.[3, 6].

In an ideal radio channel, the received signal would consist of only a single direct path signal, which would be a perfect reconstruction of the transmitted signal. However in a real channel, the signal is modified during transmission in the channel. The received signal consists of a combination of attenuated, reflected, refracted, and diffracted replicas of the transmitted signal.

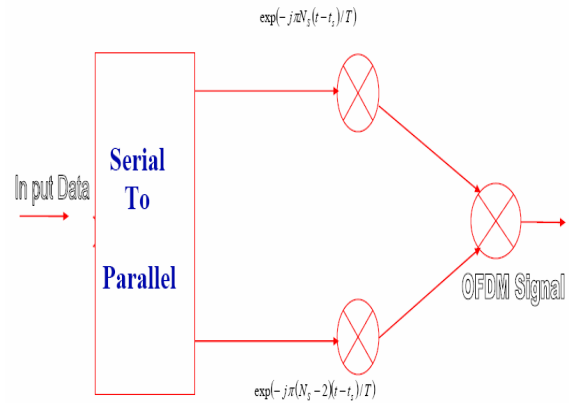

Figure2: OFDM modulator

On top of all this, the channel adds noise to the signal and can cause a shift in the carrier frequency if the transmitter or receiver is moving (Doppler Effect). Understanding of these effects on the signal is important because the performance of a radio system is dependent on the radio channel characteristics.

2. WIRELESS TRANSMISSION SYSTEM DRAWBACKS

2.1 Multiple Path Effect & Rayleigh Fading System

The RF signal from the transmitter may be reflected from objects such as hills, buildings, or vehicles. This gives rise to multiple transmission paths at the receiver. The relative phase of multiple reflected signals can cause constructive or destructive interference at the receiver. This is experienced over very short distances (typically at half wavelength distances), thus is given the term fast fading. These variations can vary from 10-30dB over a short distance [3]. The Rayleigh distribution is commonly used to describe the statistical time varying nature of the received signal power [5]. It describes the probability of the signal level being received due to fading.



2.2 Delay Spread

The received radio signal from a transmitter consists of typically a direct signal, plus reflections of object such as buildings, mountings, and other structures. The reflected signals arrive at a later time than the direct signal because of the extra path length, giving rise to a slightly different arrival time of the transmitted pulse, thus spreading the received energy. Delay spread is the time spread between the arrival of the first and last multipath signal seen by the receiver. In a digital system, the delay spread can lead to inter-symbol interference. This is due to the delayed multipath signal overlapping with the following symbols. This can cause significant errors in high bit rate systems. Figure 3 & figure 4 show the effect of inter-symbol interference due to delay spread on the received signal, when there is no multipath and with multipath channel. As the transmitted bit rate is increased the amount of intersymbol interference also increases. The effect starts to become very significant when the delay spread is greater than $\sim 50\%$ of the bit time [6]. The maximum delay spread in an outdoor environment is approximately $20\mu\text{sec}$, thus significant intersymbol interference can occur at bit rates as low as 25kbps [6].

Inter-symbol interference can be minimized in several ways. One method is to reduce the symbol rate by reducing the data rate for each channel (i.e. split the bandwidth into more channels using frequency division multiplexing OFDM) [5].

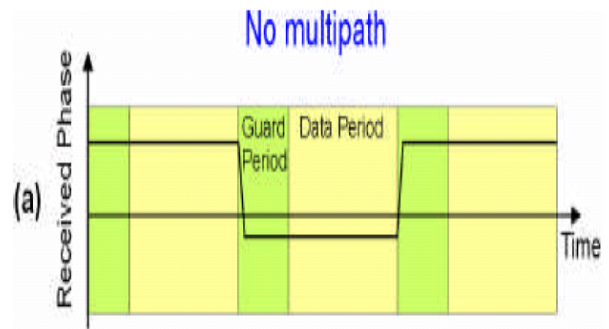

Figure 3: Function of guard period when No multipath

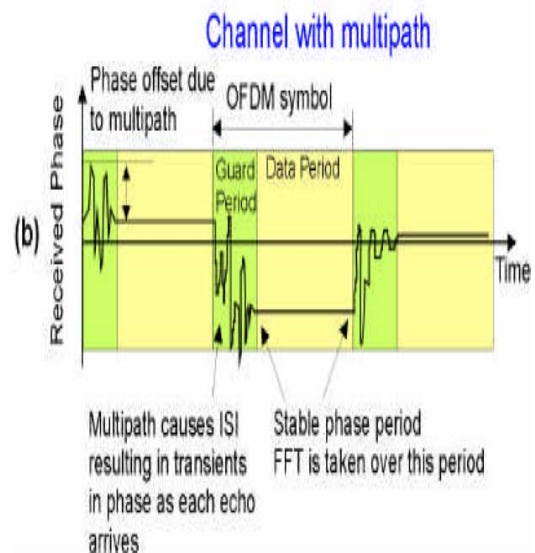

Figure 4: Function of guard period for protecting against ISI when channel with multipath

2.3 Protection against Inter Symbol Interference (ISI)

In an OFDM signal the amplitude and phase of the subcarrier must remain constant over the period of the symbol in order for the subcarriers to maintain orthogonality.



If they are not constant it means that the spectral shape of the subcarriers will not have the correct sinc shape, and thus the nulls will not be at the correct frequencies, resulting in Inter-Carrier Interference. At the symbol boundary the amplitude and phase change suddenly to the new value required for the next data symbol. In multipath environments ISI causes spreading of the energy between the symbols, resulting in transient changes in the amplitude and phase of the subcarrier at the start of the symbol. The length of these transient effects corresponds to the delay spread of the radio channel. The transient signal is a result of each multipath component arriving at slightly different times, changing the received subcarrier vector. Fig.2 and Figure5 show this effect. Adding a guard period allows time for the transient part of the signal to decay, so that the FFT is taken from a steady state portion of the symbol.

This eliminates the effect of ISI provided that the guard period is longer than the delay spread of the radio channel. The remaining effects caused by the multipath, such as amplitude scaling and phase rotation are corrected for by channel equalization.

The addition of guard period removes most of the effects of ISI; however in practice, multipath components tend to decay slowly with time, resulting in some ISI even when a relatively long guard period is used [7].

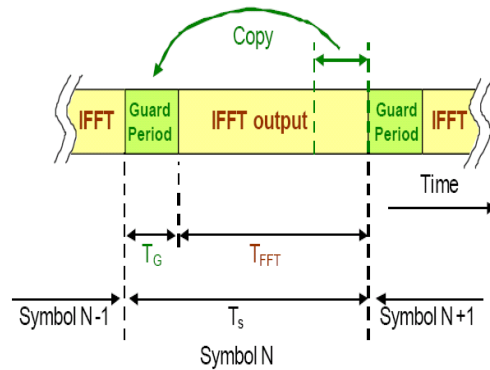

Figure 5: Addition of a guard period to an OFDM signal

2.4 Doppler Shift

When a wave source and the receiver moving relative to one another, the received frequency signal will not be the same as the source. When they move toward each other the frequency of the received signal is higher than the source, and when they are approaching each other the frequency decreases. This is called the Doppler Effect. The amount the frequency changes due to the Doppler Effect depends on the relative motion between the source and receiver and on the speed of propagation of the wave. The Doppler shift in frequency can be written [5, 6]:

$$\Delta f \approx \pm f_o \frac{v}{c} \quad (3)$$

Where: -

Δf is the change in frequency of the source seen at the receiver

f_o is the frequency of the source, v and c are the speed difference between the source and transmitter and c is the speed of light, respectively.

Doppler shift can cause significant problems if the transmission technique is sensitive to carrier frequency offsets or the relative speed is higher, which is the case for OFDM.



3. OFDM MODELING & SIMULATION SYSTEM

Mathematically, the OFDM signal is expressed as a sum of the prototype pulses shifted in time- and frequency and multiplied by the data symbols. In continuous-time notation, the k-th OFDM symbol is written as [7, 9]: -

$$S_{RF,K}(t-KT) = R_e \left[w(t-KT) \sum_{i=-\frac{N}{2}}^{\frac{N}{2}-1} X_{i,k} e^{j2\pi(f_c + \frac{i}{T_{FFT}})(t-KT)} \right] \quad (4)$$

$$KT - T_{win} - T_{guard} \leq t \leq KT + T_{FFT} + T_{win}$$

$$S_{RF,K} = 0 \quad \text{Otherwise}$$

Where:

T Symbol length; time between two consecutive OFDM symbols

T_{FFT} FFT-time; effective part of the OFDM symbol

T_{guard} Guard-interval; duration of the cyclic prefix

T_{win} Window-interval; duration of windowed prefix/postfix for spectral shaping

f_c Center frequency of the occupied frequency spectrum

$F = 1/T_{FFT}$ Frequency spacing between adjacent sub-carriers

N FFT-length; number of FFT points

K index on transmitted symbol

i index on sub-carrier; $i \in \{-N/2, -N/2+1, \dots, -1, 0, 1, \dots, N/2-1\}$

$X_{i,k}$ Signal constellation point; complex {data, pilot, null} symbol modulated on the I_{th} sub carrier of the K_{th} OFDM symbol.

W(t) denotes the transmitter pulse shape defined as

$$W(t) = \frac{1}{2} \left[1 - \text{COS} \pi(t + T_{win} + T_{guard}) / T_{win} \right]$$

$$-T_{win} - T_{guard} \leq t < -T_{guard} \quad \text{Or}$$

$$W(t) = 1 \quad -T_{guard} \leq t \leq T_{FFT}$$

Or

$$W(t) = \frac{1}{2} \left[1 + \text{COS} \pi(t - T_{FFT}) / T_{win} \right]$$

$$T_{FFT} < t \leq T_{FFT} + T_{win} \quad (5)$$

Finally, continuous sequence of transmitted OFDM symbols is expressed as

$$S_{RF}(t) = \sum_{k=-\infty}^{\infty} S_{(RF,K)}(t-KT) \quad (6)$$

The OFDM system was modeled and simulated using MATLAB & Simulink to allow various parameters of the system to be varied and tested, including those established by the standard as shown in block diagram 1. The simulation includes all the stages for transmitter, channel and receiver, according to the standard. Because of the MATLAB sampling time, the transmission was implemented in baseband to avoid long periods of simulation. Considering additive white gaussian noise (AWGN) and multipath path Rayleigh fading effect, a good approximation to the real performance can be observed, over all in the degradation of the BER. At the transmitter, OFDM signals are generated by Bernoulli Binary and mapped by one of the modulation techniques. Then by using a Sequence Generation, The transmitter section converts digital data to be transmitted, into a mapping of sub carrier amplitude and phase. It then transforms this spectral representation of the data into the time domain using an Inverse Fast Fourier Transform (IFFT). The OFDM



symbol is equal to the length of the IFFT size used (which is 1024) to generate the signal and it has an integer number of cycles. The Cyclic Prefix and Multiple Parameters were added before the signal conversion from Parallel to Serial mode. The addition of a guard period to the start of each symbol makes further improvement to the effect of ISI on an OFDM signal. For generation an OFDM signal, all the model variables parameters were setting in suitable values in order to have smooth generated signal to be transmitted. The channel simulation will allow for us to examine the effects of noise and multipath on the OFDM scheme. By adding small amount of random data of AWGN to the transmitted signal, noise can be simulated. Multipath simulation involves adding attenuated and delayed copies of the transmitted signal to the original. This simulates the problem in wireless communication when the signal propagates on many paths. For example, a receiver may see a signal via a direct path as well as a path that bounces off of a building. Digital raised cosine filter was designed to recover channel impairments.

At the transmission channel the signal is subjected to multipath Rayleigh fading system with the following parameters: -

Maximum Doppler Shift (Hz) is 200

Sample Time is (8e-5/180) second

Delay Vector(s) is [0-8e-5]

Gain Vector is [0-3] Db

Also the data is subjected to Additive White Gaussian Noise (AWGN) with the following parameters: -

Mode is Signal to Noise Vector (E_s / N_o)

E_s / N_o is Varied according to the different types of modulation techniques used.

In put Signal Power in watts is (2.8e-6)

In the complex signals, the AWGN Channel block relates E_b / N_o , E_s / N_o and SNR according to the following equations [1]:

$$E_s / N_o = SNR \cdot (T_{sym} / T_{samp}) \quad (7)$$

$$E_s / N_o = E_b / N_o + 10 \text{Log}_{10}(k) \text{ in Db} \quad (8)$$

Where: -

E_s = Signal energy in joules

E_b = Bit energy in joules

N_o = Noise power spectral density (watts/Hz)

T_{sym} = is the symbol period parameters of the block in Es/No mode
 K = is the number of information bits per input symbol

T_{samp} = is the inherited sample time of the block, in seconds.

The receiver performs the reverse operation of the transmitter, mixing the RF signal to base band for processing, then using a Fast Fourier Transform (FFT) to analyze the signal in the frequency domain. The amplitude and phase of the sub carriers is then picked out and converted back to digital data.

Data to be transmitted is typically in the form of a serial data stream. In OFDM, each symbol typically transmits 40 - 4000 bits, and so a serial to parallel conversion stage is needed to convert the input serial bit stream to the data to be transmitted in each OFDM symbol. The data allocated to each symbol depends on the modulation scheme used and the number of sub carriers. For example, data rate of sub carrier modulation of BPSK is 1 bit, 1bit/Hz for QPSK, 2 bits/Hz for DQPSK, 2 bits/Hz for DBPSK, 4 bits/Hz for 8 PSK, and 4 bits/Hz for 16 PSK [2,9].



Figure6 show the transmitted power spectrum when using DQPSK as modulation scheme.

The aim of doing the simulations was to measure the performance of OFDM under different channel conditions, and to allow for different OFDM configurations to be tested. [1] This effectively raised cosine filters the signal, removing some of the OFDM side-lobes. The amount of side-lobe removal depends on the sharpness of the filters used. In general digital filtering provides a much greater flexibility, accuracy and cut off rate than analogue filters making them especially useful for band limiting of an OFDM signal [4, 8]. The work has been focused on the DQPSK. Figure7 and figure8 show the received signal power spectrum before and after filtering. The figures show how the system deals with the present of the transmission drawbacks, under filtering.

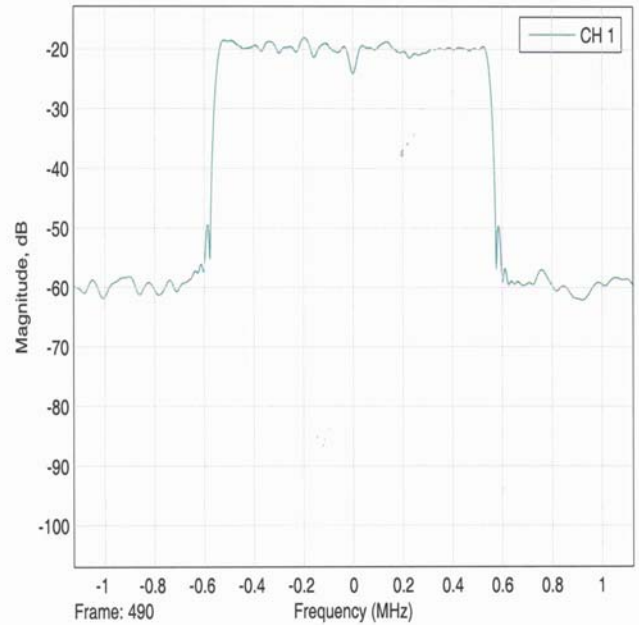

Figure7: The received signal power spectrum before filtering

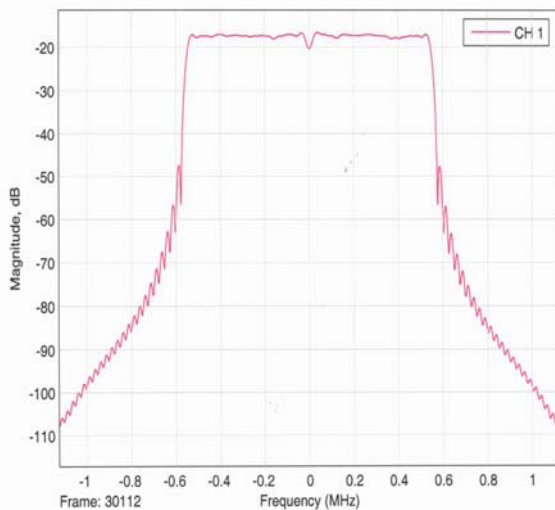

Figure 6: DQPSK transmitted signal power spectrum

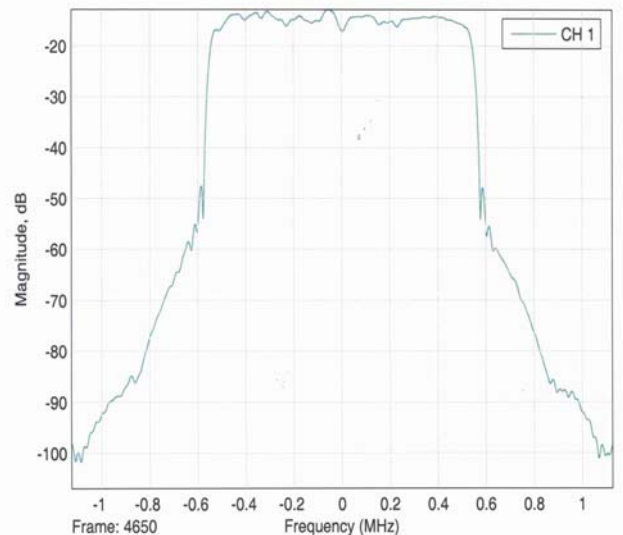
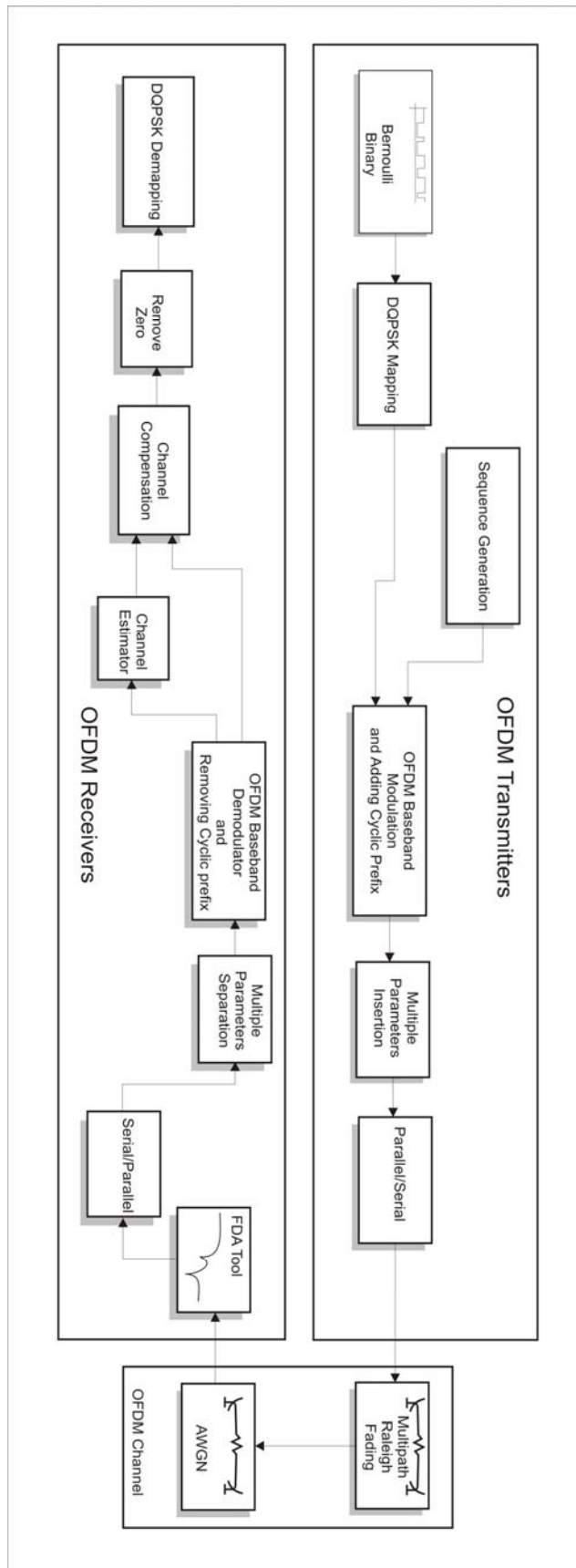

Figure 8: The received signal power spectrum after filtering



Block diagram 1: Model of Un-coded OFDM

4. CONCLUSION

According to the simulations, OFDM appears to be a good modulation technique for high performance wireless communications. Also with reference to the result found from simulation; DQOSK achieved excellent result by receiving smooth signal quality and high channel capacity without affecting the main transmitted signal. Therefore OFDM is one of the most capable broadband modulation schemes, and it has the following key advantages: -

- 1- It makes efficient use of the spectrum by allowing overlap
- 2- By dividing the channel into narrowband flat fading sub channels, OFDM is more resistant to frequency selective fading.
- 3- It eliminates ISI through use of a cyclic prefix and several types of adaptive modulations.
- 4- It is least sensitive to sample timing offset.

REFERENCES

1. Eric Philip Lawrey, "Adaptive Techniques for Multi-users OFDM", James cooks University, December 2001
2. Anibal Luis Intinid, "Orthogonal Frequency Division Multiplexing for Wireless Networks", University of California, December 2000, <http://www.engineering.Ucsb.edu>
3. Tevelik. Yuck, "Self – interference Handling in OFDM Based Wireless Communication System", University of South Florida, College of Engineering, November 2003.
4. Klaus Witraisal, "OFDM Air-Interface Design for Multimedia



-
- Communications”, Austria 2002,
<http://www.polypo.com>.
5. Yi Sun, “Bandwidth-Efficient
Wireless OFDM”, IEEE,
November 2001
 6. Theodore Rappaport, “Wireless
Communications Principal and
Practice”. 1999
 7. William Stallings, “Wireless
Communications and Networking”,
Prentice Hall UK, 2002

8. B.P.Lathi, “Modern Digital and
Analogue Communication
Systems”, New York, Oxford
University Press, 1998
9. Klaus Witrissal, “OFDM Air
Interface Design For Multimedia
Communications”, Australia, April
2002 1998

